

TR-UP08-B-IN Pole Mount Adapter



Specifications

Bracket	TR-UP08-B-IN
Application	Indoor or outdoor, pole installation for PTZ dome camera
Dimensions(L x W x H)	215mmx172mmx65mm(8.5" x 6.8"x 2.6")
Embrace hoop diameter	67mm~127mm(2.6"~5")
Weight	0.55kg(1.2lb)
Material	Aluminum alloy

Dimensions

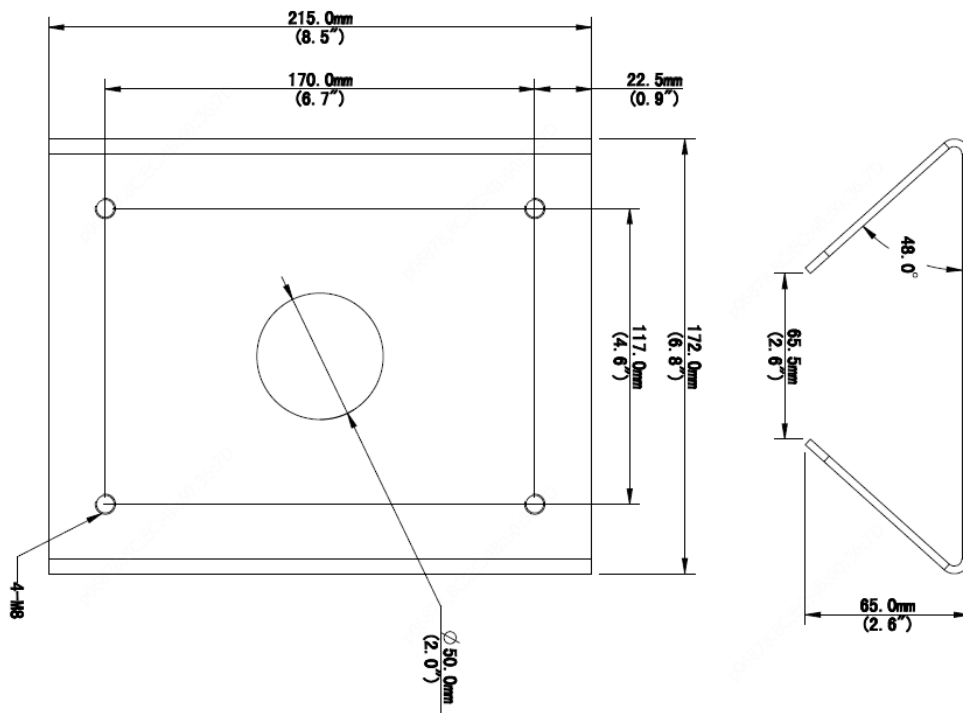

Zhejiang Uniview Technologies Co.,Ltd.

South Tower, Building 10, Wanlun Science Park, 88 Jiangling Road, Hangzhou, P.R.China 310051

Email: overseasbusiness@uniview.com; globalsupport@uniview.com

<http://www.uniview.com>

©2015-2020 Zhejiang Uniview Technologies Co.,Ltd. All rights reserved.

*Product specifications and availability are subject to change without notice.