

# Bullet&Dome Corner Mounting Bracket

TR-UC08-C

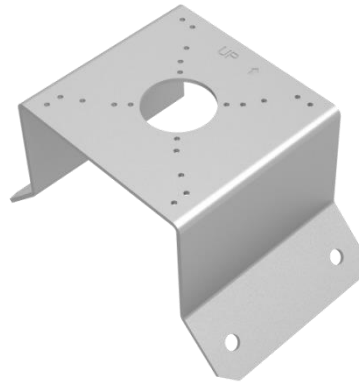

## Specifications

Bracket	TR-UC08-C
Application	Corner installation
Dimensions(L x W x H)	137mmx127mmx116mm(5.4" x 5.0"x 4.6")
Weight	0.42kg(0.93lb)
Material	Aluminum alloy

## Dimensions

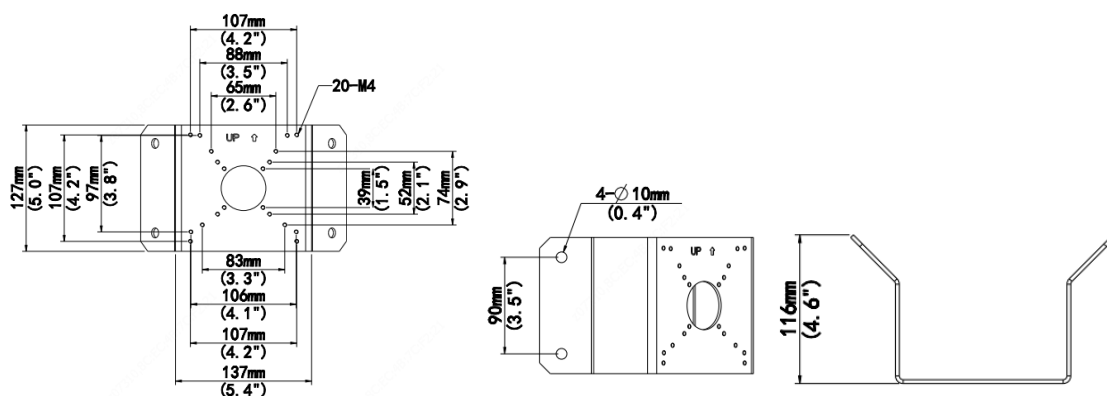

**Zhejiang Uniview Technologies Co.,Ltd.**

South Tower, Building 10, Wanlun Science Park, 88 Jiangling Road, Hangzhou, P.R.China 310051

Email: [overseasbusiness@uniview.com](mailto:overseasbusiness@uniview.com); [globalsupport@uniview.com](mailto:globalsupport@uniview.com)

<http://www.uniview.com>

©2022 Zhejiang Uniview Technologies Co.,Ltd. All rights reserved.

\*Product specifications and availability are subject to change without notice.